

Dati soggetti a variazione senza obbligo di preavviso
Edizione 04/2020 © 2020 JMG Cranes S.p.A. Tutti i diritti riservati
Rev.1 - 04/2020



Electric Pick & Carry Cranes



MC 450S (metric)
Portata Massima
45.000 kg

**Tecman**

MC 450S

TRAZIONE SULLE RUOTE ANTERIORI CON CONTROROTAZIONE

BRACCIO IDRAULICO CON USCITA PROPORZIONALE

STERZATURA 180° SU RUOTE POSTERIORI

ZAVORRE REMOVIBILI

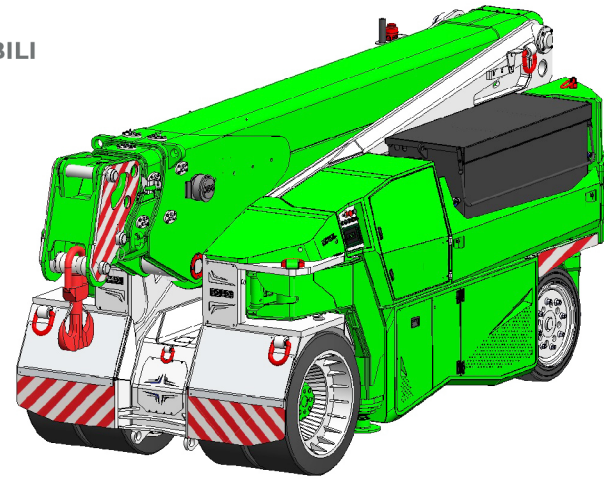

Optionals:

- ARGANO IDRAULICO
- JIB IDRAULICO
- JIB MECCANICO CON PROLUNGA
- MECCANICA
- RUOTE ANTISTRACCIA
- STABILIZZATORI FRONTALI A COMPASSO
- FORCA IDRAULICA
- TRASFORMAZIONI
- ANTIDEFLAGRANTI
- COLORE PERSONALIZZATO



Informazioni tecniche

Portata Massima kg	45.000
Dimensioni mm	4900x2200x2415

Trazione anteriore. N°2 motori elettrici AC 16 kW 96V. Classe d'isolamento H	LMI. Sistema elettronico indicatore del carico e limitatore del momento ribaltante
Complessivo Kg. 36.700 Zavorre removibili Kg. 10.600	Sistema automatico di frenatura su tutte le ruote
96 V - 1550 Ah 8 ore di autonomia	In robusta lamiera d'acciaio di qualità piegata e saldata
Anteriori n.4 cushion 40x16-30" Posteriori n.4 superelastiche 355/50-15"	Angolo di inclinazione +63°/-5°
Posteriore Angolo di sterzo -90°/+90°	Motore elettrico impianto idraulico 1x45 kW - 96 V AC, 1x23 kW - 96 AC.

Diagrammi di portata

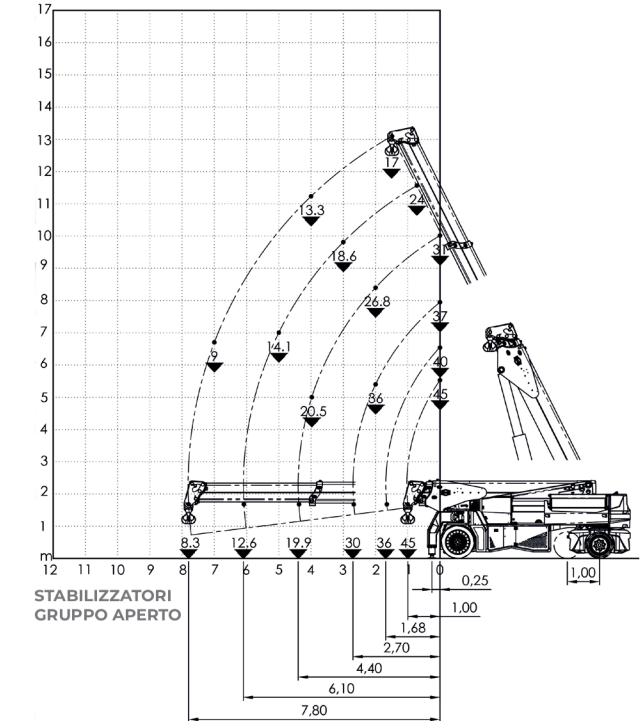
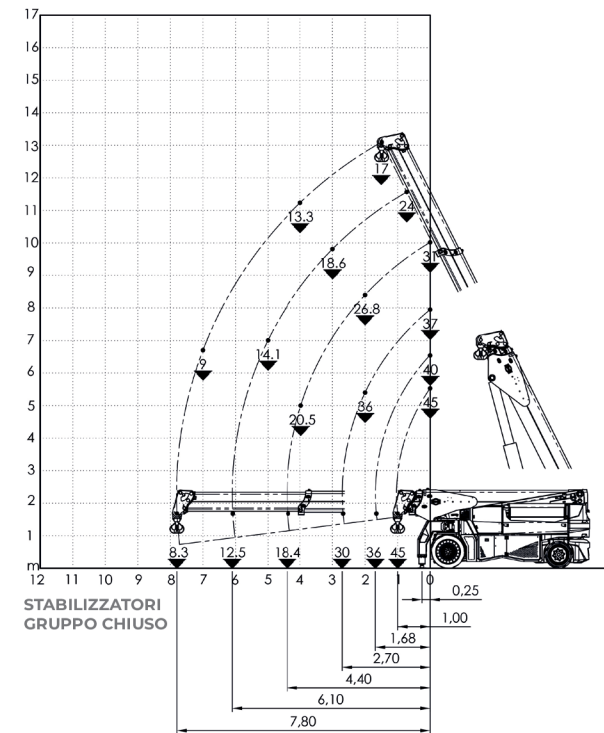
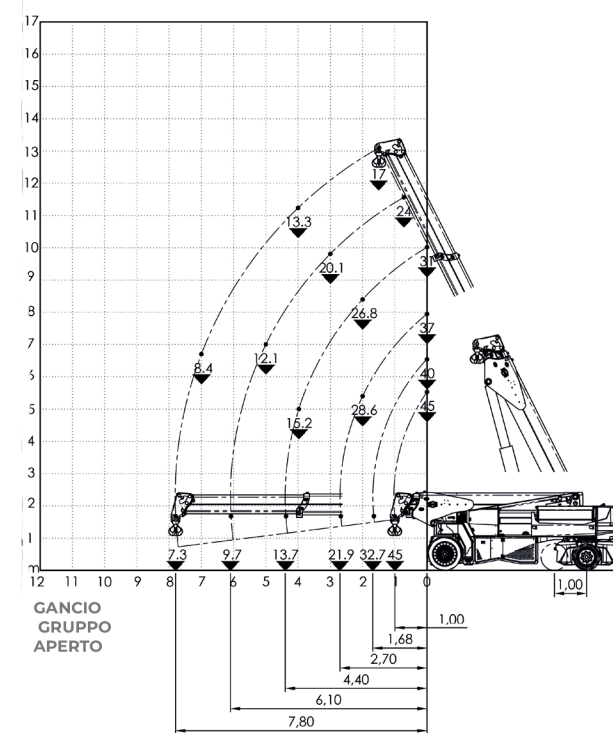
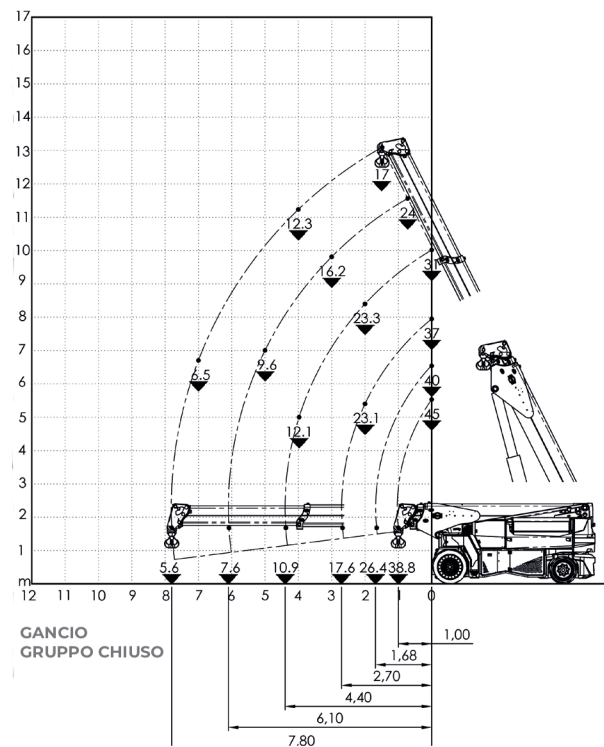

Normative

	UNI ISO 4301-2: A1
	2006/42 CE-2014/30 UE-2014/35 UE- 2000/14 e successive modifiche
	EN 13000:2014 ANSI/ASME B30.5-2011 e successive modifiche



Dimensioni di ingombro

